

Compact Fresh-cut Dryer



Compact Fresh-cut Dryer with lid open

Key's [Compact Fresh-cut Dryer](#) provides a flexible solution for removing water from a wide range of fresh-cut produce, enhancing your product quality and extending shelf life. Simple and efficient, the centrifugal design provides adjustable speed and time settings to optimize drying for leafy greens, cut vegetables, and herbs. Solid and dependable, the Compact Fresh-cut Dryer functions perfectly with Key's [Fresh-cut Basket Wash](#) and [AVSealer Packaging and Sealing Machine](#) to give you a full processing and packaging solution.

Flexibility

- Fully adjustable drum speed and spin time settings
- Small footprint and isolation supports for convenient placement and easy moves
- Three wash/dry baskets included; basket liner available separately for fine cut sizes

Reliability

- AB controls for consistent setup and operation
- NEMA 4x control enclosure
- Reliable, heavy duty timing belt drive system
- Bottom, non-plugging water drain
- 1-year limited warranty, wear parts and labor excluded

Performance

- Capacity ranges up to 820 kg (1800 lbs) per hour
- Variable speed drive provides a range of drum speeds up to 850 rpm
- Dependable electronic braking stops drum in under 4 seconds
- Ergonomic basket lift heights
- Sized for safe lifting weights up to 13.6 kg (30 lbs)
- Safety interlock prevents lid from opening until the drum has stopped
- Wash-down duty stainless steel construction



Compact Fresh-cut Dryer used together with Key's Wash System

Key Technology

150 Avery Street • Walla Walla, WA 99362 • USA

Phone: 509.529.2161 • Fax: 509.527.1331 • product.info@key.net • www.key.net



Compact Fresh-cut Dryer Specifications

• Key Part Number 840381

Basket

- 44 liter (11.6 gallons)
- Molded, food-grade plastic
- Average opening size 7.5 mm x 9 mm (19/64" x 23/64"), 47% open space
- Compact Dryer ships with three baskets

Drum speed

- From zero to 850 rpm

Power

- 0.75 kw motor (1 hp)
- 230 volt, single phase, 20 amps

Construction

- Stainless steel

Weight

- 116 kg (255 lbs)

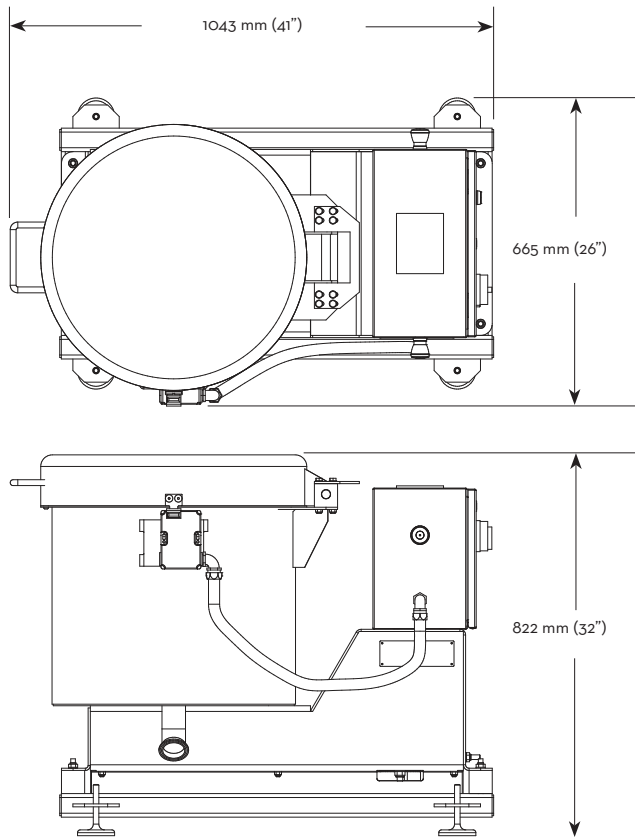

Capacity kg/hr (lb/hr)

Product	Basket Weight kg (lb)	Dry Time (seconds)			
		30	60	90	120
Shredded Iceberg/Cabbage	10.9 (24)	700 (1545)	455 (1000)	340 (750)	270 (600)
Chopped Iceberg	9.1 (20)	580 (1275)	375 (825)	285 (625)	225 (500)
Chopped Romaine	8.2 (18)	520 (1150)	340 (750)	250 (550)	205 (450)
Baby Spinach	6.4 (14)	410 (900)	260 (575)	215 (475)	170 (375)
Spring Mix	5.4 (12)	350 (775)	225 (500)	170 (375)	135 (300)
Cut Vegetables	12.7 (28)	815 (1800)	535 (1175)	400 (875)	315 (700)
Herbs	3.6 (8)	225 (500)	150 (325)	115 (250)	90 (200)

Constant Parameters: Average Load and Unload Time = 9 s each, Start-up and Breaking Time = 8 s total.

Part Number Description

- O23737 Blue basket, diameter 490 mm (19"), height 430 mm (17"), food-grade plastic
- O27286 Basket liner, 420 mm x 350 mm (16.5" x 13.75"), 1000 micron polyester

Call Key for price and delivery information

Basket Liner Specifications

- Fiber: Polyester monofilament
- Mesh opening: 1000 microns
- Thread count: 6.7 per cm (17 per inch)
- Thread diameter: 508 microns
- Open area: 45%
- Finish: Conveyor belt/food-grade washed

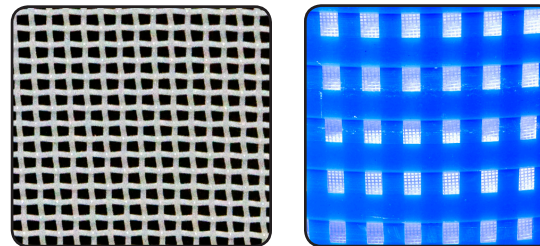

Basket with Liner Installed