

# Iso-Flo®

## Vibratory Conveyors

# ISO-FLO®

Key® wrote the book on vibratory innovation over twenty-five years ago and Iso-Flo® has revolutionized the way processors transport product. Today, Key® provides continuing value with Smart Shaker® improvements for Iso-Flo®.

### Reliability

Taking superior reliability to a new level, Iso-Flo® now includes:

- Five year warranty
- Strong Arm™ spring arms



The standard five year warranty is an industry first: the culmination of years of experience, solid engineering, and attention to manufacturing detail.

[Strong Arm™ spring arms](#) provide up to twice the life of previous arms, are resistant to catastrophic failure, and give more consistent performance.

### Sanitation

The innovation continues as Key® introduces these sanitation improvements for Iso-Flo®:

- Stainless Steel Iso-Drive®
- Patented Removable Slide Gate
- Design & construction for worldwide regulatory standards

The [stainless steel Iso-Drive®](#) reduces corrosion compared to traditional cast mild steel drives. Iso-Flo® shakers also feature a patented removable slide gate that allows for easy and thorough cleaning. Key® designs & manufactures Iso-Flo® to satisfy the most stringent sanitation demands, meeting 3A Dairy Sanitary Standards, USDA and FDA requirements, and NEMA 4X washdown specifications.

### Engineered to fit

Key® has built a reputation for custom-engineering creative solutions for difficult conveying problems, and also offers Iso-Flo® in standard models for quicker delivery. Iso-Flo® can be designed to handle multiple products and various capacities, giving maximum line flexibility, while maintaining efficiency.



**Key Technology**

150 Avery Street • Walla Walla, WA 99362 • USA

Phone: 509.529.2161 • Fax: 509.527.1331 • [product.info@key.net](mailto:product.info@key.net) • [www.key.net](http://www.key.net)



## Operational Performance

Applications for Iso-Flo® in both processing and packaging include:

- [Alignment](#)
- [Distribution](#)
- [Fines Removal](#)
- [Scalping](#)
- [Dewatering](#)
- [Inspection](#)
- [Grading](#)
- [Scale Feed](#)
- and other applications as needed

Iso-Glide™ conveyors, designed to limit vertical acceleration to less than 1g, simulate horizontal motion and prevent product loft and bounce. Iso-Glide™ reduces product damage, seasoning loss, and product noise, and decreases product buildup making sanitation faster. [Iso-Flo® Smooth Cycle™](#) is a scale feed conveyor that improves on-demand feeding performance by eliminating the mechanical stop/start transients common in scale feed applications.

Iso-Flo® uses independent, frame-mounted drive and spring arm assemblies that distribute energy equally to all parts of the conveyor bed in a controlled natural-frequency operation. This operating principle minimizes vibration transferred to the structural support, reducing the cost of installation and enabling the conveyor to be installed exactly where it is most beneficial—suspended from overhead, supported from the floor, mounted to other machinery, or even on movable casters. This design also reduces energy consumption, maintenance, and offers quiet operation.

## Process Control & Connectivity

Key's [SmartArm®](#) is a revolutionary tool that prevents down time, reduces labor, and improves process efficiencies. By wirelessly measuring and reporting vibratory stroke and speed, SmartArm® provides an at-a-glance, compiled analysis of shaker function. Alerts are provided through the software for any measurements outside of normal. Trending data is collected and displayed, allowing better plant operating decisions. The innovative Smart-Arm®, added to Key's industry leading warranty, makes Iso-Flo® a compelling choice for your vibratory needs.

[Forté Modular Controls](#) provide a single point of power and control for simple to complex processing and packaging lines for optimal efficiency.

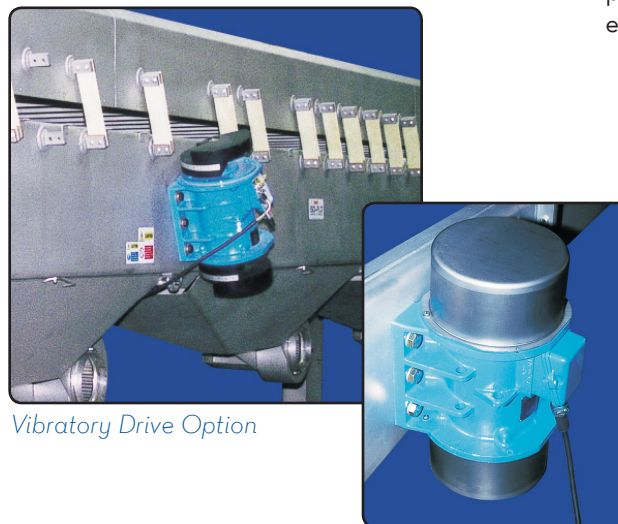

*Vibratory Drive Option*



*SmartArm® Installed on an Iso-Flo®*

## Complete Line of Conveyor Solutions

Iso-Flo® leads an extensive family of vibratory conveying solutions including [Impulse™ electromagnetic](#), [Horizon™ horizontal](#), [Marathon long-distance](#), and [Spiral-Flo® vertical elevating](#). All provide unique, complete-line capabilities in concert with Key®'s processing and optical equipment, together with industry-best expertise and service.

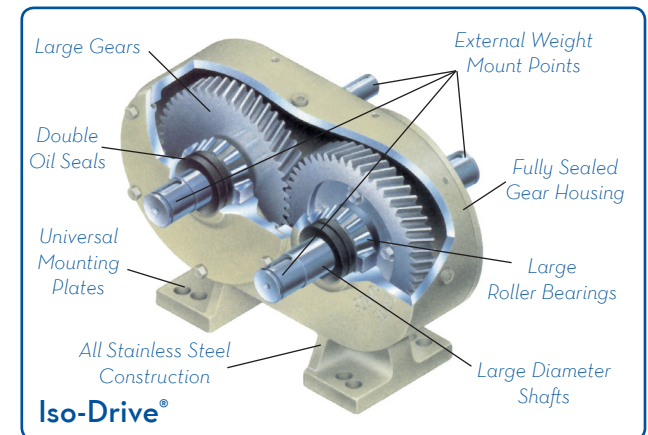

**Iso-Drive®**