

# Horizon™

## Horizontal Motion Conveyor

## HORIZON

- Gentle, quiet conveying
- Self-cleaning action / easy sanitation
- Low product damage / seasoning loss
- Energy-efficient operation
- Unique maintenance-free drive
- Minimized footprint / height requirements
- Single conveyor up to 100 ft (30m)
- Speeds up to 42 ft/min (13m/min)

Horizon horizontal motion conveyor maximizes product quality with gentle, no-damage handling and clean operation. Its smooth movement is ideal for fragile, seasoned, coated and frozen food products.



### Continuous Self-Cleaning

Horizontal motion produces a constantly self-cleaning action, avoiding buildup of coatings, oils or seasonings and preventing mixing and size separation of product. All-stainless construction and simple wipe-down make sanitation fast.

### Product Protection

Slow-forward/quick-back motion minimizes vertical product movement and eliminates breakage, coating loss and condiment buildup.

### Power and Efficiency

Horizon's drive moves product up to 100 ft (30 m) on a single continuous conveyor - at speeds up to 42 ft/minute (13 m/min). The drive features low power usage and the conveyor itself conserves space with minimal footprint and height demands.

### Maintenance-Free Reliability

Horizon's lubed-for-life mechanical drive, backed by Key's industry-leading 5-year warranty, provides effortless, trouble-free operation and long equipment life.



Key Technology

150 Avery Street • Walla Walla, WA 99362 • USA

Phone: 509.529.2161 • Fax: 509.527.1331 • [product.info@key.net](mailto:product.info@key.net) • [www.key.net](http://www.key.net)



## Optional Features

- Custom and standard slide gates, pivot gates and proportional gates
- Bias, flared, and conical discharges for smooth product transfer
- [Forté control](#) integration services

*Horizon's mechanical drive unit can be mounted anywhere along the length of the pan, including behind it. It is available in two sizes to minimize power consumption and is usable with different pans.*

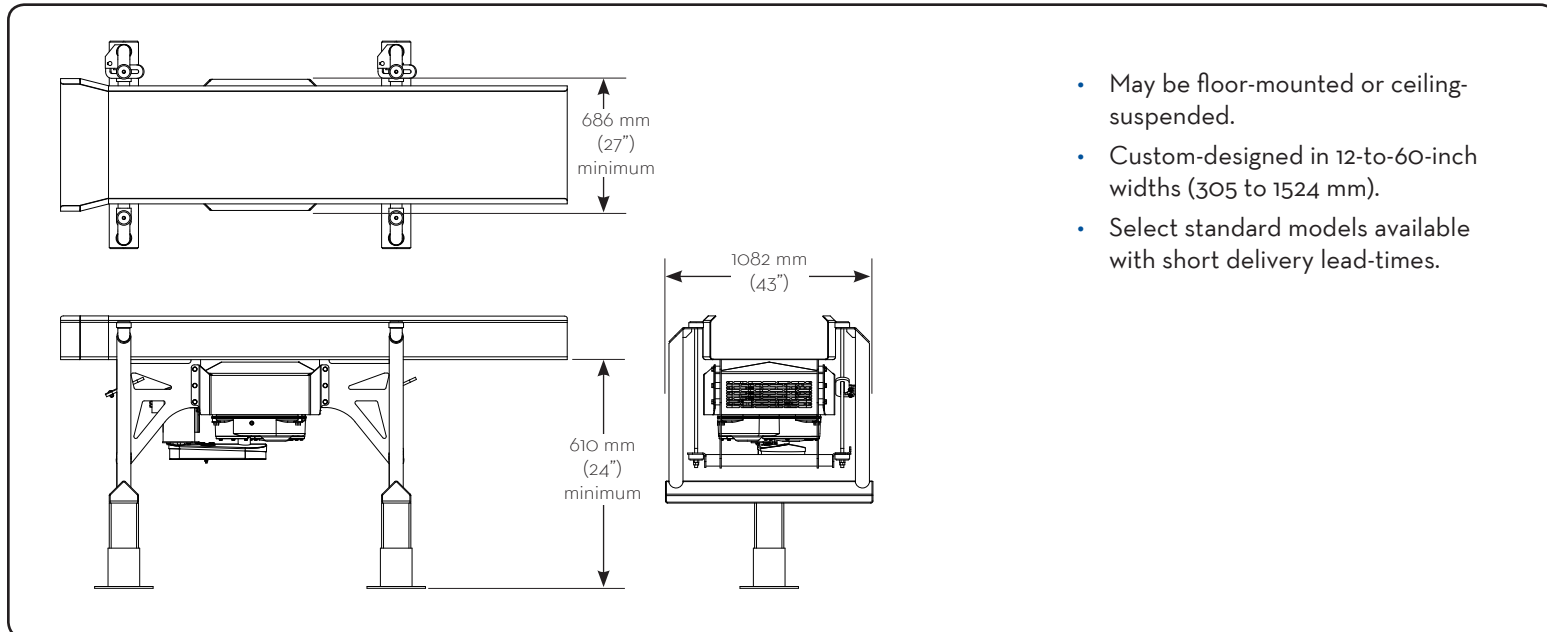
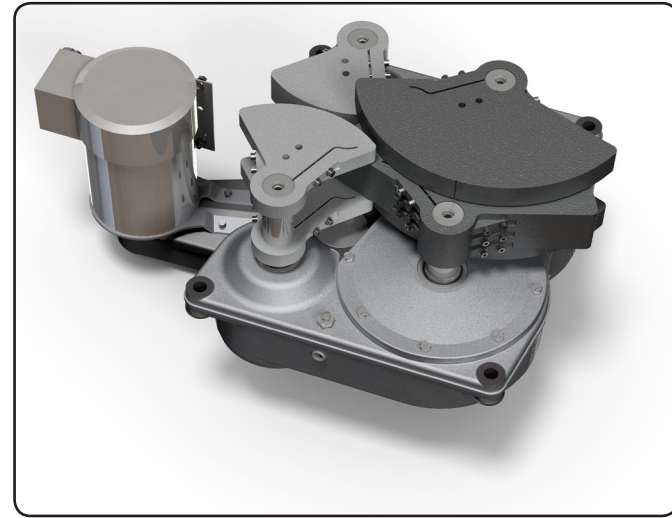

- May be floor-mounted or ceiling-suspended.
- Custom-designed in 12-to-60-inch widths (305 to 1524 mm).
- Select standard models available with short delivery lead-times.